

EN54-24 Wall Mount Speaker WSK-420HWEN

Feature:

- Compliant with the EN54-24 standards
- Commercial public address speaker with transformer
- Ideal for school, office, hotel and airport background music system
- Power output 20-10-5-2.5W & 8Ω
- 4" woofer and 1" silk tweeter two way speaker system
- ABS fire-resistant enclosure, metal grille in white
- Fire-resistant phoenix terminal, thermal fuse and 95°C fire-resistant cable
- Quick installation by supplied stainless mounting bracket



EN54-24

Specification:

Model	WSK-420HWEN
Description	EN54-24 Wall Mount Speaker
Power Taps	20-10-5-2.5W & 8Ω
Line Input	100V or 70V & 8Ω
Frequency Response	100-20KHz
SPL(@1W/m)	88±3dB
IP Rate	IP55 waterproof rate
Speaker Unit	4" woofer and 1" silk tweeter two way speaker system
Dimension	245×170×140mm
Material	ABS fire-resistant enclosure, metal grille in white
Mounting Way	Quick installation by supplied stainless mounting bracket
Net Weight	2.5kg

Side View & Dimension:

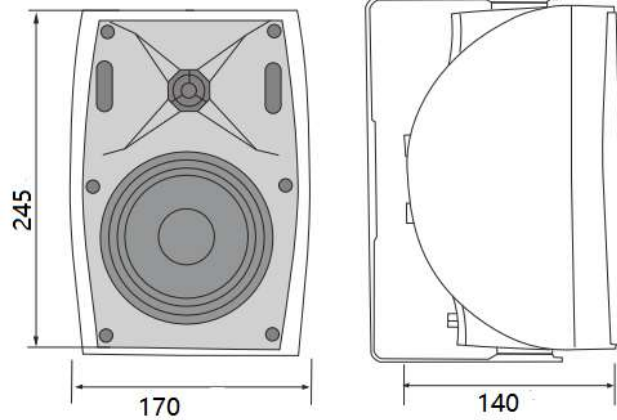
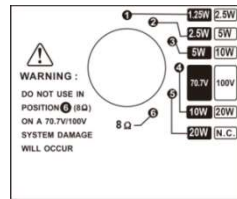

Impedance VS SPL Diagrams:

